

# 350 MACHINE

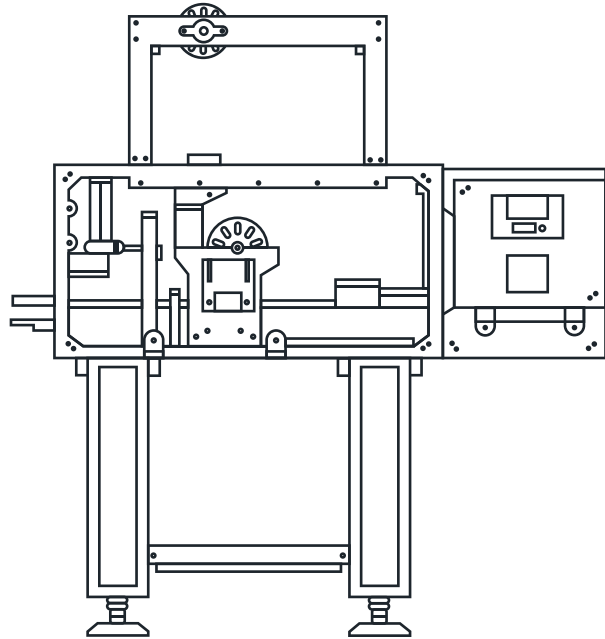

The 350 machine uses proven rotary technology to apply can carriers in a way that meets the needs of entry-speed canning operations. The machine is designed to be flexible, modifying to pack multiples, adjusting to different can sizes, and adapting to line changes, including conveyor height

- Automatic Operation
- 12oz & 16oz
- 5 Minute Changeover
- Full Guard Package
- Can Down Sensor
- Up To 60 Cpm
- 4,6 And 8 Packs
- 2-wide Discharge
- 211 Cans



**RINGS: RIM APPLIED**

**WX3200 (3200 Count Roll)**

## MACHINE FACTS

<b>MACHINE LENGTH</b>	54"
<b>MACHINE WIDTH</b>	35"
<b>MACHINE ACCESS PANELS</b>	OPENS WITH 1/4 TURN FASTENERS, TETHERED TOOL
<b>HEIGHT</b>	71" AT 36" CONVEYOR HT.
<b>VOLTAGE</b>	110-120 VAC
<b>SERVICE AMPS</b>	12 @ 110 VAC
<b>PHASE</b>	SINGLE
<b>CYCLE</b>	60HZ

<b>WATER (GAL/HR)</b>	NONE REQUIRED
<b>AIR (SCFM @75 PSI)</b>	NONE REQUIRED
<b>OPERATOR INTERFACE</b>	UNITRONICS JAZZ
<b>PLC TYPE</b>	UNITRONICS JAZZ
<b>FAULT IDENTIFICATION</b>	YES
<b>REMOTE ACCESS</b>	N/A
<b>INTERLOCKS</b>	N/A

1155 TIMBER DRIVE ELGIN, IL 60123 | WWW.HELIO-PACK.COM | 800.446.7225

CONTACT MIKE BURNS: MBURNS@MUMMPROD.COM 847.508.7688