

# 450 MACHINE

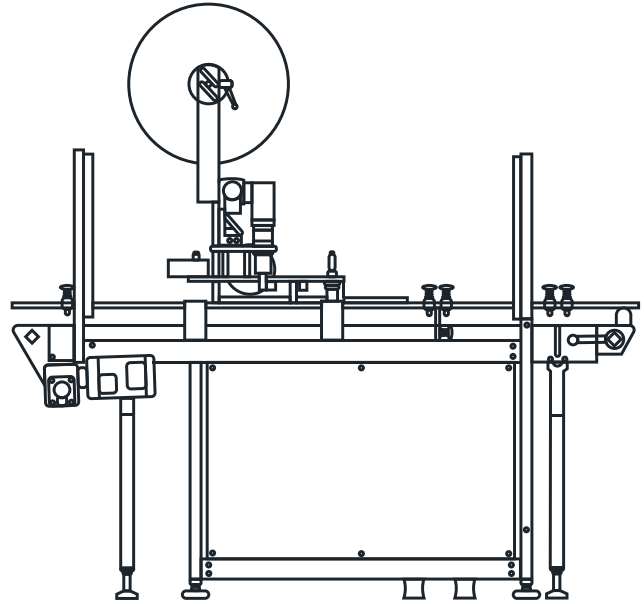

The 450 machine is the next generation of our rotary-applied carrier machines for canning production lines. This high-speed unit uses a straight-through conveyor design to apply carrier rings at a rate of 280 cans per minute. Quick changeover allows for adjusting to 12-oz, 16-oz, and 19.2-oz cans within minutes.

- Automatic Operation
- 280 Cpm
- 4,6 And 8 Pack Capable
- 211 Cans 12oz, 16oz Or 19.2oz
- 2 Wide Infeed And Discharge
- Straightline Feed Operation
- Light Curtains For Easy Access
- 15 Minute Changeover



## RINGS: ROLLS

WX3200 (3200 Count Roll)

## MACHINE FACTS

<b>MACHINE LENGTH</b>	96.3"
<b>MACHINE WIDTH</b>	45"
<b>MACHINE ACCESS PANELS</b>	LIGHT CURTAIN GUARDING FOR FULL SIDE ACCESS
<b>HEIGHT</b>	107" AT 40" CONVEYOR HT.
<b>VOLTAGE</b>	240-VAC
<b>SERVICE AMPS</b>	30 @ 240 VAC
<b>PHASE</b>	SINGLE
<b>CYCLE</b>	60HZ

<b>WATER (GAL/HR)</b>	NONE REQUIRED
<b>AIR (SCFM @75 PSI)</b>	NONE REQUIRED
<b>OPERATOR INTERFACE</b>	PANASONIC GT707
<b>PLC TYPE</b>	PANASONIC FPSIGMA
<b>FAULT IDENTIFICATION</b>	YES WITH HISTORY
<b>REMOTE ACCESS</b>	N/A
<b>INTERLOCKS</b>	AVAILABLE

1155 TIMBER DRIVE ELGIN, IL 60123 | WWW.HELIO-PACK.COM | 800.446.7225

CONTACT MIKE BURNS: MBURNS@MUMMPROD.COM 847.508.7688