

550 MACHINE

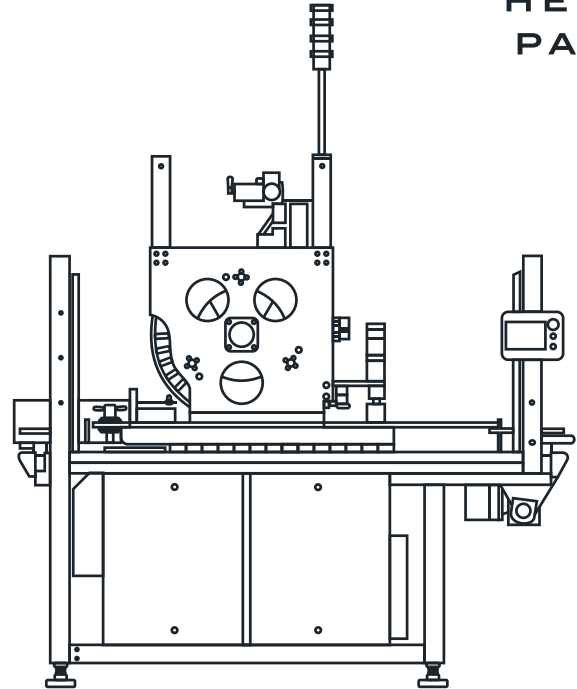

The 550 machine is the next generation of our rotary-applied carrier machines for canning production lines. This high-speed unit uses a straight-through conveyor design to side-apply rings at a rate of up to 250 cans per minute. Quick changeover allows for adjusting to 12-oz, 16-oz, and 19.2-oz cans within minutes.

- Automatic Operation
- 2 Wide Infeed And Discharge
- Straightline Feed Operation
- Light Curtains For Side Access
- 5 Minute Changeover
- Up To 250 Cpm
- Side Applied Carrier Only
- 4,6 And 8 Pack Capable
- 211 Cans 12oz, 16oz Or 19.2oz



RINGS: FAN FOLD SIZE

ZC1092-109,200 6-PACKS PER PALLET

MACHINE FACTS

MACHINE LENGTH	97.9"
MACHINE WIDTH	45.4"
MACHINE ACCESS PANELS	LIGHT CURTAIN GUARDING FOR FULL SIDE ACCESS
HEIGHT	120.2" AT 41.75" CONVEYOR HT.
VOLTAGE	240-VAC
SERVICE AMPS	50A @ 240 VAC
PHASE	SINGLE
CYCLE	60HZ

WATER [GAL/HR]	NONE REQUIRED
AIR [SCFM @75 PSI]	NONE REQUIRED
OPERATOR INTERFACE	PANASONIC GT707
PLC TYPE	PANASONIC FPSIGMA
FAULT IDENTIFICATION	YES WITH HISTORY
REMOTE ACCESS	N/A
INTERLOCKS	AVAILABLE

1155 TIMBER DRIVE ELGIN, IL 60123 | WWW.HELIO-PACK.COM | 800.446.7225

CONTACT MIKE BURNS: MBURNS@MUMMPROD.COM 847.508.7688