

350 MACHINE

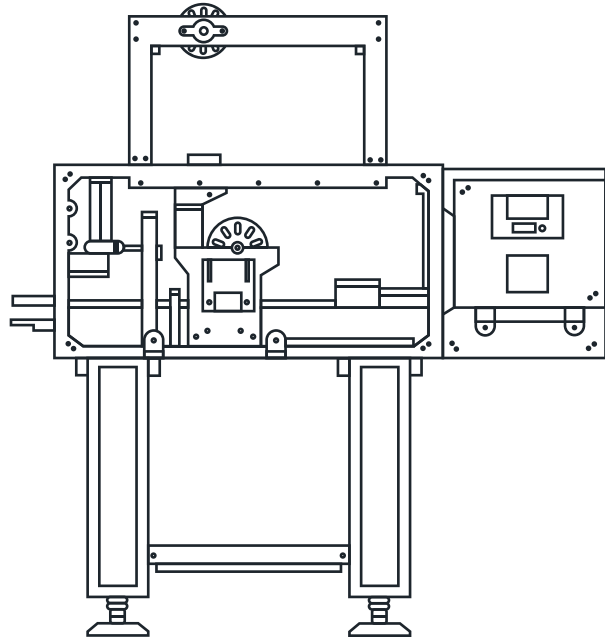

The 350 machine uses proven rotary technology to apply can carriers in a way that meets the needs of entry-speed canning operations. The machine is designed to be flexible, modifying to pack multiples, adjusting to different can sizes, and adapting to line changes, including conveyor height

- Automatic Operation
- 12oz & 16oz
- 5 Minute Changeover
- Full Guard Package
- Can Down Sensor
- Up To 75 Cpm
- 4,6 And 8 Packs
- 2-wide Discharge
- 211 Cans



RINGS: RIM APPLIED

WX3200 [3200 Count Roll]

MACHINE FACTS

MACHINE LENGTH	54"
MACHINE WIDTH	35"
MACHINE ACCESS PANELS	OPENS WITH 1/4 TURN FASTENERS, TETHERED TOOL
HEIGHT	71" AT 36" CONVEYOR HT.
VOLTAGE	110-120 VAC
SERVICE AMPS	12 @ 110 VAC
PHASE	SINGLE
CYCLE	60HZ

WATER [GAL/HR]	NONE REQUIRED
AIR [SCFM @75 PSI]	NONE REQUIRED
OPERATOR INTERFACE	UNITRONICS JAZZ
PLC TYPE	UNITRONICS JAZZ
FAULT IDENTIFICATION	YES
REMOTE ACCESS	N/A
INTERLOCKS	N/A

1155 TIMBER DRIVE ELGIN, IL 60123 | WWW.HELIO-PACK.COM | 800.446.7225

CONTACT MIKE BURNS: MBURNS@MUMMPROD.COM 847.508.7688